

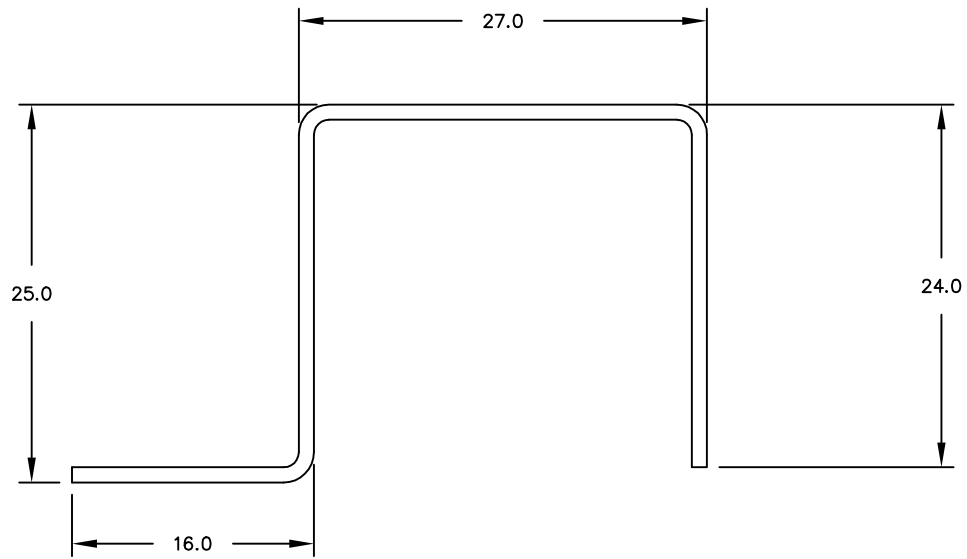

STAR AUTO INDUSTRIES  
G/2,G/3,G/8 ANSA INDUSTRIAL ESTATE  
SAKI VIHAR ROAD, SAKI NAKA

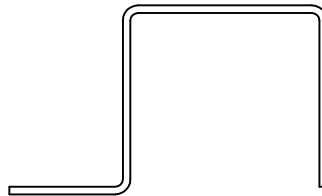

SCALE 2:1



SCALE 1:1

FRONT PILLAR SUPPORT EXTENSION

COMPANY : MAHINDRA & MAHINDRA

PROJECT : CHAMPION



STAR AUTO INDUSTRIES  
G/2,G/3,G/8 ANSA INDUSTRIAL ESTATE  
SAKI VIHAR ROAD, SAKI NAKA

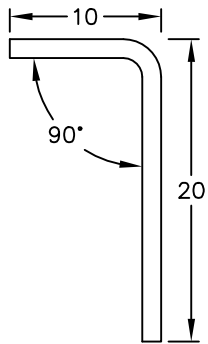

SCALE 2:1

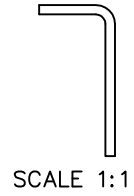

SCALE 1:1

### SIDE PANEL SUPPORT

COMPANY : MAHINDRA & MAHINDRA

PROJECT : CHAMPION

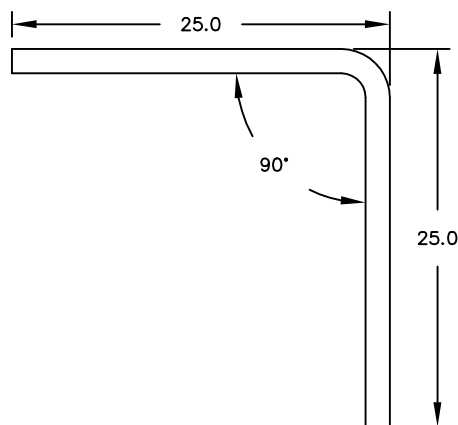

SCALE 2:1

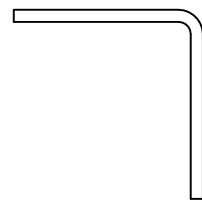

SCALE 1:1

### REINFORCEMENT SUPPORT

COMPANY : MAHINDRA & MAHINDRA

PROJECT : CHAMPION



STAR AUTO INDUSTRIES  
G/2,G/3,G/8 ANSA INDUSTRIAL ESTATE  
SAKI VIHAR ROAD, SAKI NAKA

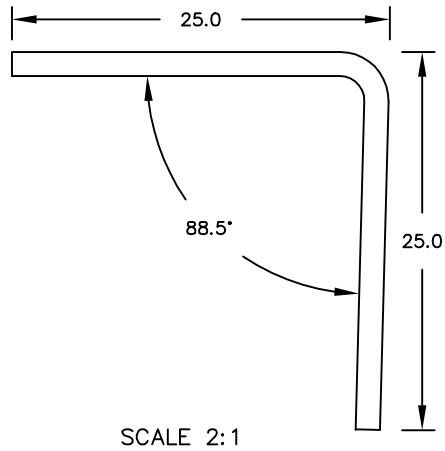

### REINFORCEMENT SUPPORT

COMPANY : MAHINDRA & MAHINDRA

PROJECT : CHAMPION

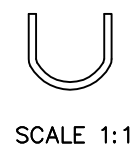
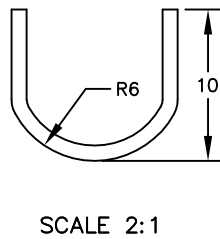

### QUARTER GLASS INNER

COMPANY : PREMIER AUTOMOBILES

PROJECT : PREMIER PADMINI



STAR AUTO INDUSTRIES  
G/2,G/3,G/8 ANSA INDUSTRIAL ESTATE  
SAKI VIHAR ROAD, SAKI NAKA

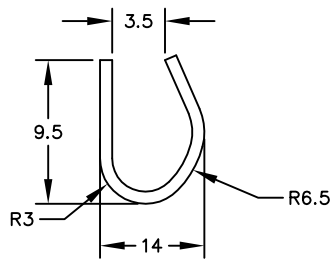

SCALE 2:1



SCALE 1:1

### SEAT TRIMMING

COMPANY : PREMIER AUTOMOBILES

PROJECT : PREMIER PADMINI

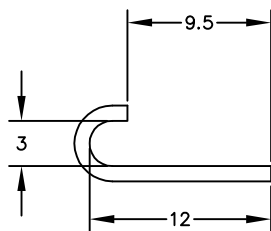

SCALE 2:1

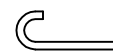

SCALE 1:1

### RETAINER

COMPANY : TATA MOTORS

PROJECT : CREW CAB



STAR AUTO INDUSTRIES  
G/2,G/3,G/8 ANSA INDUSTRIAL ESTATE  
SAKI VIHAR ROAD, SAKI NAKA

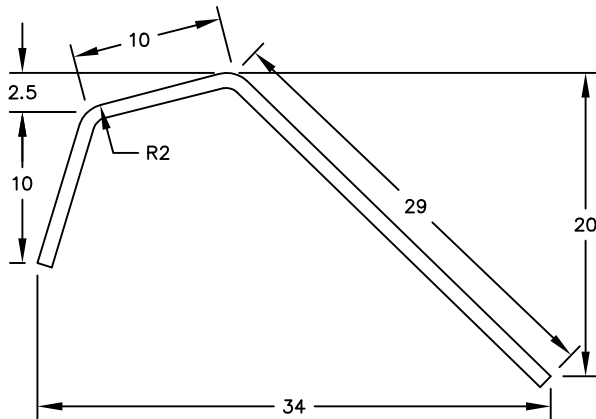

SCALE 2:1

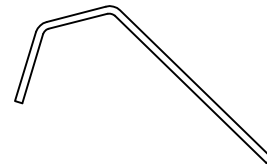

SCALE 1:1

### REINFORCEMENT DASH BOARD

COMPANY : TATA MOTORS

PROJECT : SUMO

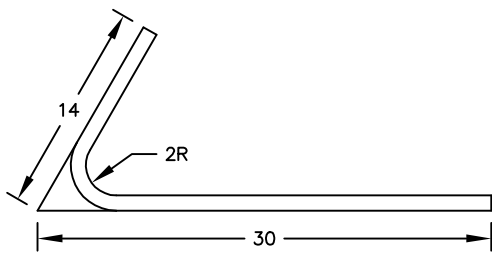

SCALE 2:1

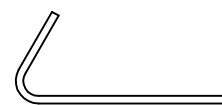

SCALE 1:1

### INNER PANNEL BOTTOM

COMPANY : TATA MOTORS



STAR AUTO INDUSTRIES  
G/2,G/3,G/8 ANSA INDUSTRIAL ESTATE  
SAKI VIHAR ROAD, SAKI NAKA

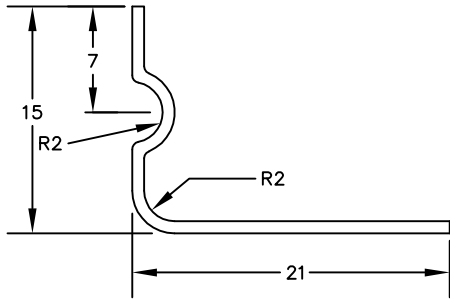

SCALE 2:1

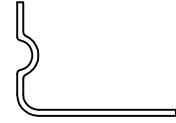

SCALE 1:1

### OUTER PANEL

COMPANY : MAHINDRA & MAHINDRA

PROJECT : VOYAGER

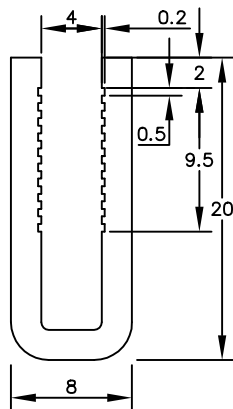

SCALE 2:1

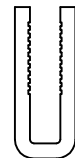

SCALE 1:1

### GRIP CHANNEL



STAR AUTO INDUSTRIES  
G/2,G/3,G/8 ANSA INDUSTRIAL ESTATE  
SAKI VIHAR ROAD, SAKI NAKA

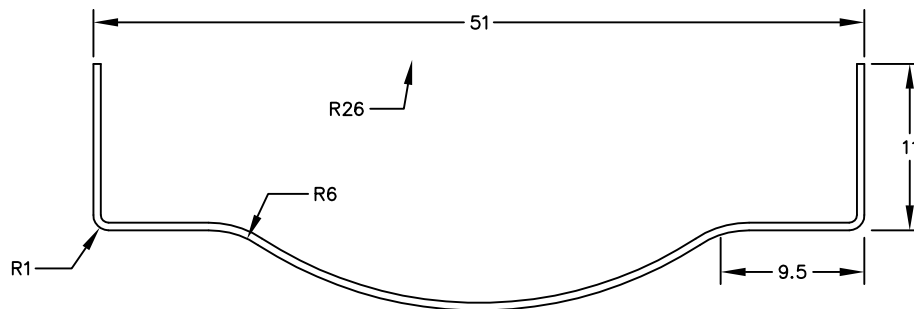

SCALE 2:1



SCALE 1:1

DECORATIVE BEADING

COMPANY : RUBY COACH



STAR AUTO INDUSTRIES  
G/2,G/3,G/8 ANSA INDUSTRIAL ESTATE  
SAKI VIHAR ROAD, SAKI NAKA

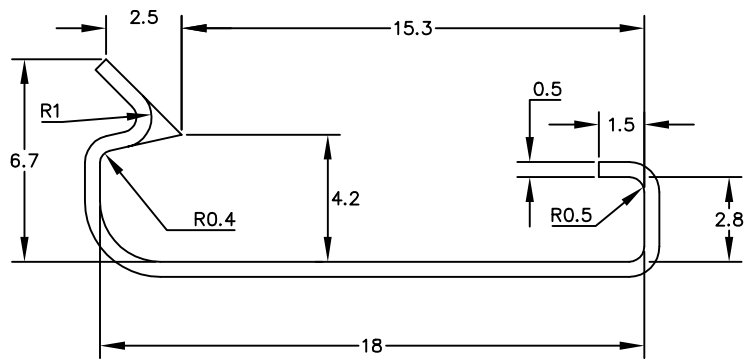

SCALE 2:1



SCALE 1:1

CHANNEL DOOR SEAL

COMPANY : TATA MOTORS

PROJECT : MIDI





STAR AUTO INDUSTRIES  
G/2,G/3,G/8 ANSA INDUSTRIAL ESTATE  
SAKI VIHAR ROAD, SAKI NAKA

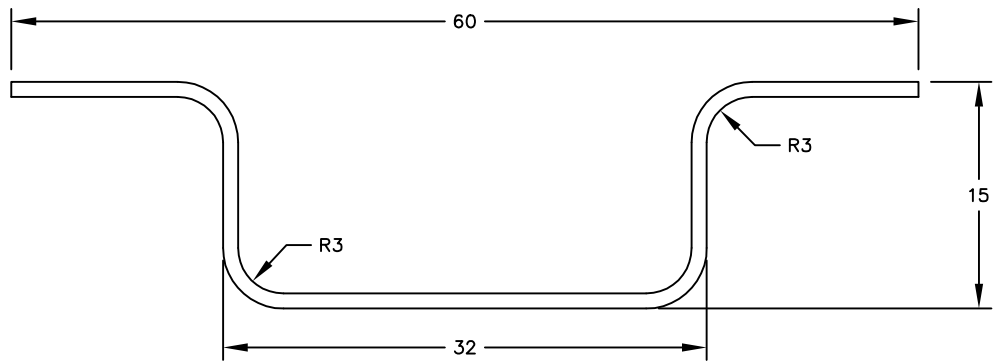

SCALE 2:1



SCALE 1:1

REINFORCEMENT END

COMPANY : TATA MOTORS

PROJECT : 1210



STAR AUTO INDUSTRIES  
G/2,G/3,G/8 ANSA INDUSTRIAL ESTATE  
SAKI VIHAR ROAD, SAKI NAKA

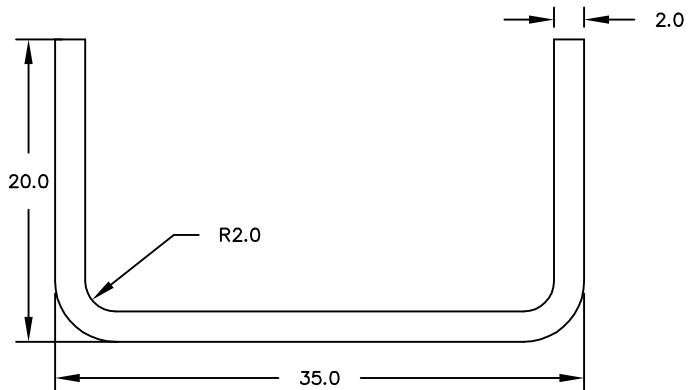

SCALE 2:1



SCALE 1:1

### REINFORCEMENT

COMPANY : MAHINDRA & MAHINDRA

PROJECT : CHAMPION

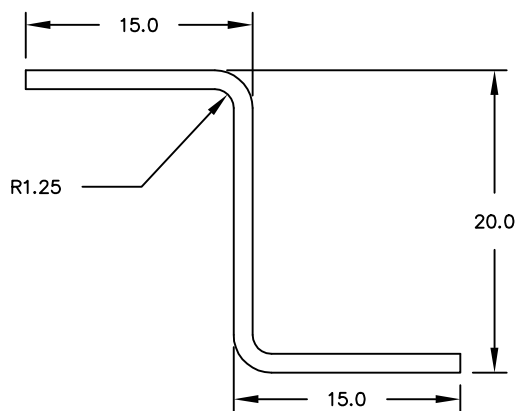

SCALE 2:1

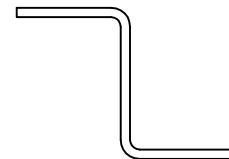

SCALE 1:1

### REINFORCEMENT

COMPANY : MAHINDRA & MAHINDRA

PROJECT : CHAMPION



STAR AUTO INDUSTRIES  
G/2,G/3,G/8 ANSA INDUSTRIAL ESTATE  
SAKI VIHAR ROAD, SAKI NAKA

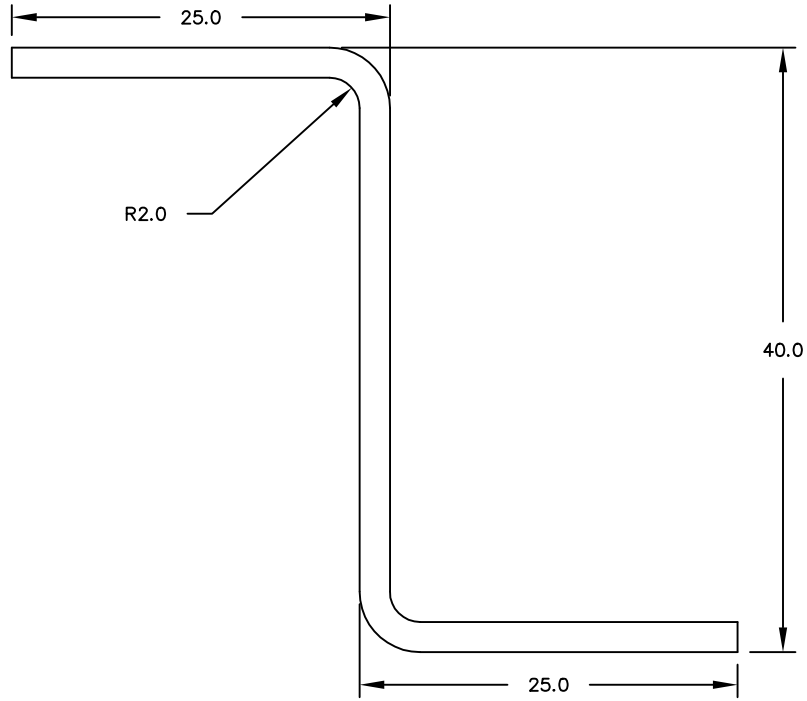

SCALE 2:1

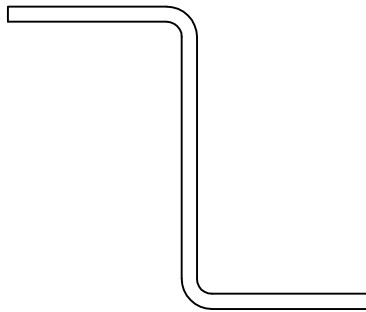

SCALE 1:1

REINFORCEMENT

COMPANY : MAHINDRA & MAHINDRA

PROJECT : CHAMPION



STAR AUTO INDUSTRIES  
G/2,G/3,G/8 ANSA INDUSTRIAL ESTATE  
SAKI VIHAR ROAD, SAKI NAKA

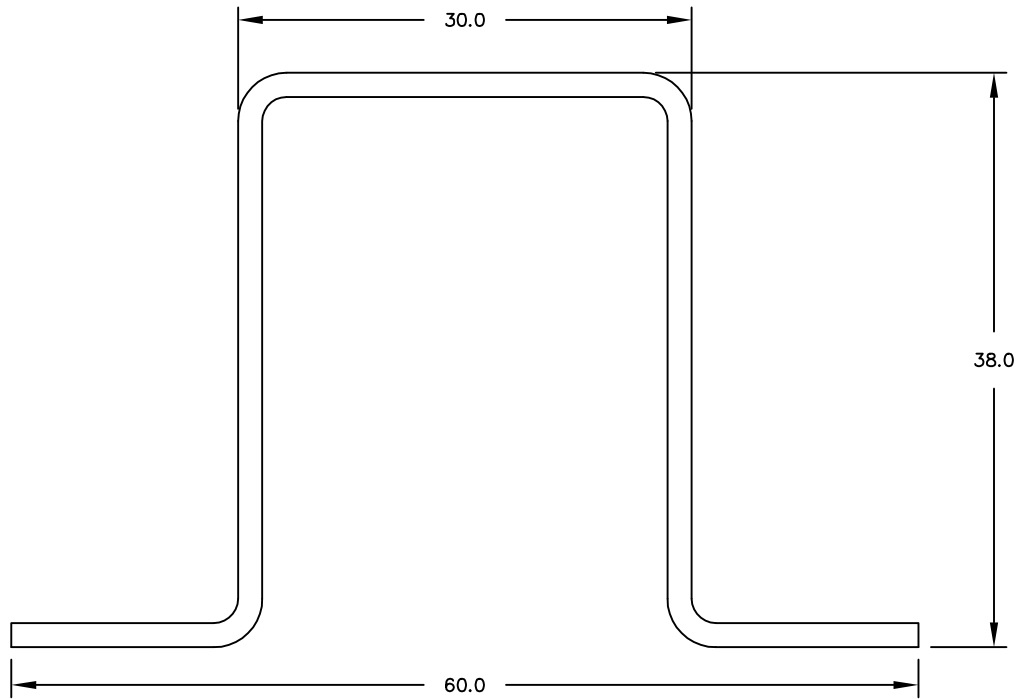

SCALE 2:1

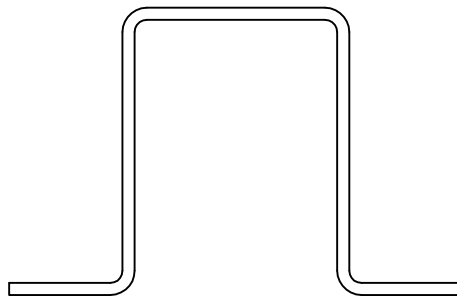

SCALE 1:1

REINFORCEMENT

COMPANY : MAHINDRA & MAHINDRA

PROJECT : CHAMPION



STAR AUTO INDUSTRIES  
G/2,G/3,G/8 ANSA INDUSTRIAL ESTATE  
SAKI VIHAR ROAD, SAKI NAKA

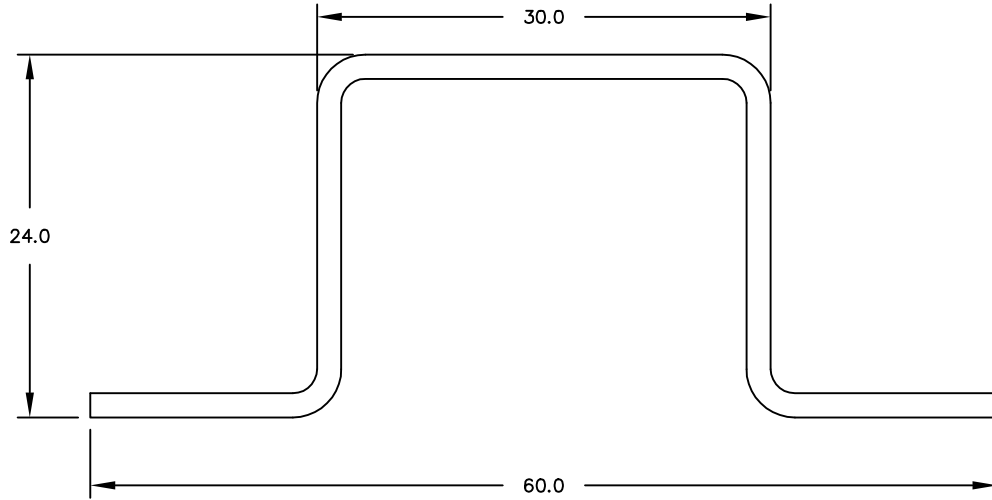

SCALE 2:1

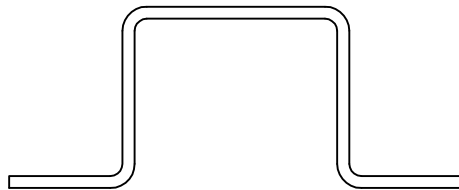

SCALE 1:1

REINFORCEMENT

COMPANY : MAHINDRA & MAHINDRA

PROJECT : CHAMPION



STAR AUTO INDUSTRIES  
G/2,G/3,G/8 ANSA INDUSTRIAL ESTATE  
SAKI VIHAR ROAD, SAKI NAKA

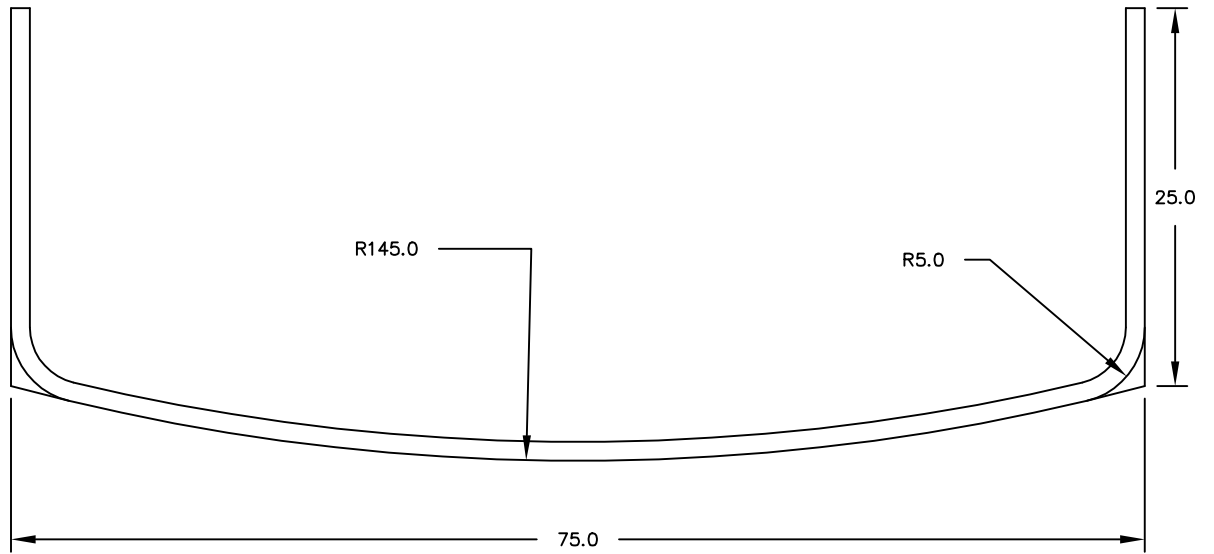

SCALE 2:1

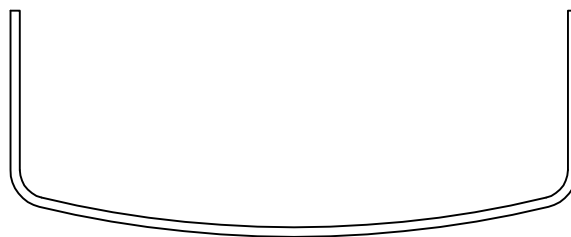

SCALE 1:1

BUMPER REAR & CORNER

COMPANY : MAHINDRA & MAHINDRA

PROJECT : CHAMPION



STAR AUTO INDUSTRIES  
G/2,G/3,G/8 ANSA INDUSTRIAL ESTATE  
SAKI VIHAR ROAD, SAKI NAKA

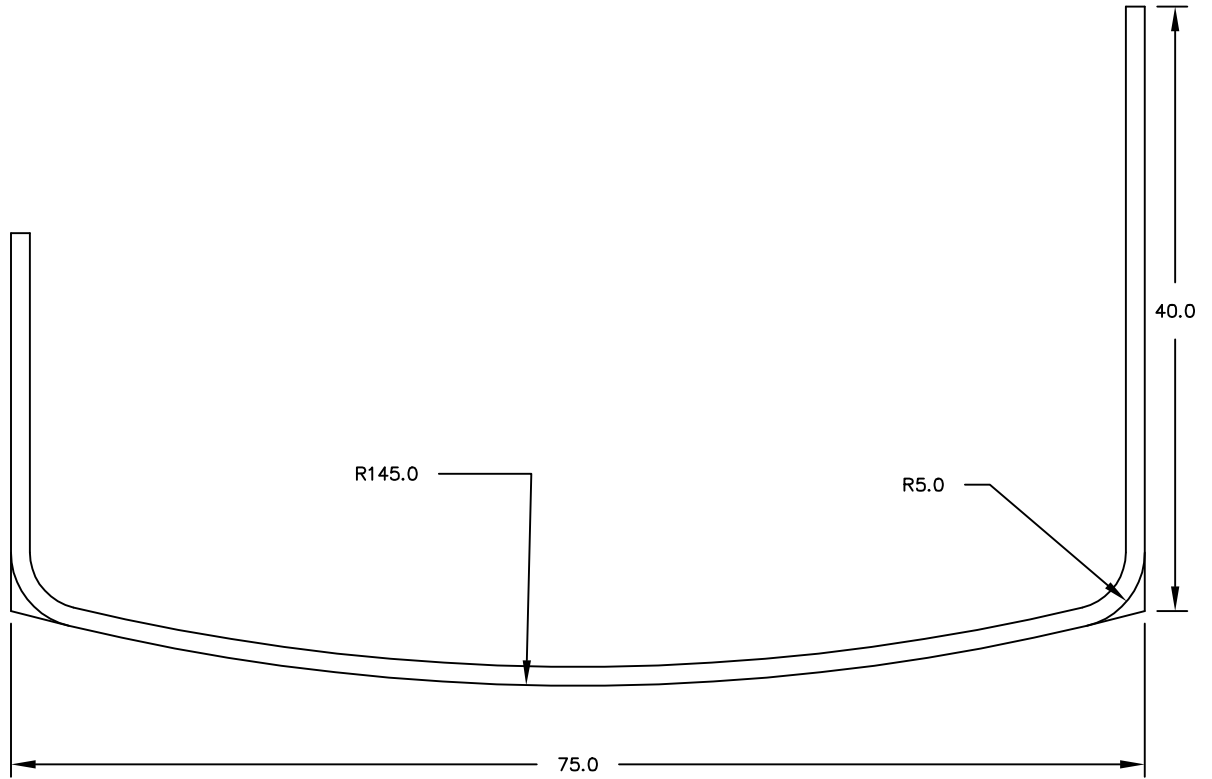

SCALE 2:1



SCALE 1:1

SIDE SILL (BUMPER SIDE)

COMPANY : MAHINDRA & MAHINDRA

PROJECT : CHAMPION



STAR AUTO INDUSTRIES  
G/2,G/3,G/8 ANSA INDUSTRIAL ESTATE  
SAKI VIHAR ROAD, SAKI NAKA

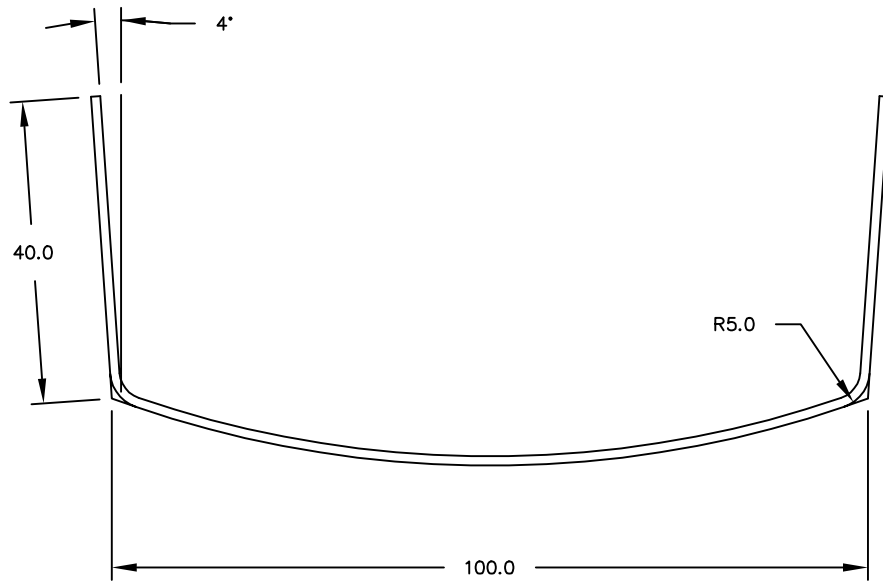

SCALE 1:1

FRONT BUMPER

COMPANY : MAHINDRA & MAHINDRA

PROJECT : CHAMPION





STAR AUTO INDUSTRIES  
G/2,G/3,G/8 ANSA INDUSTRIAL ESTATE  
SAKI VIHAR ROAD, SAKI NAKA

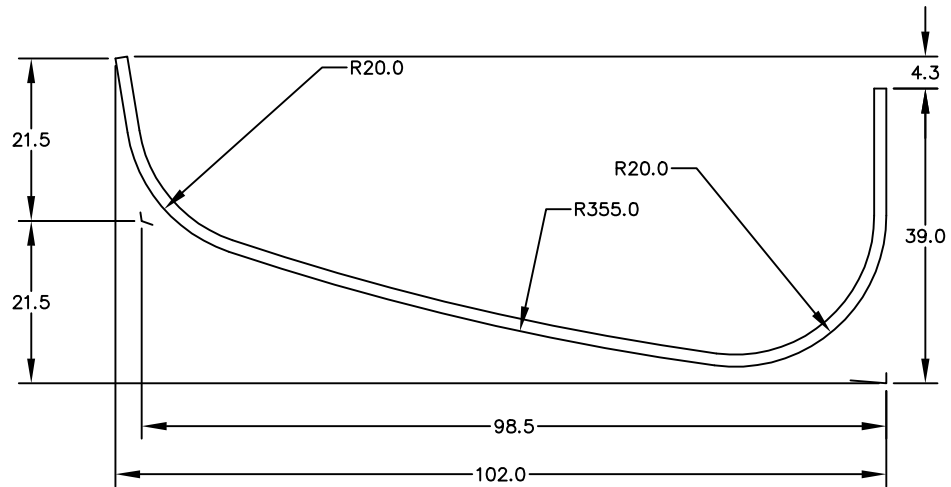

SCALE 1:1

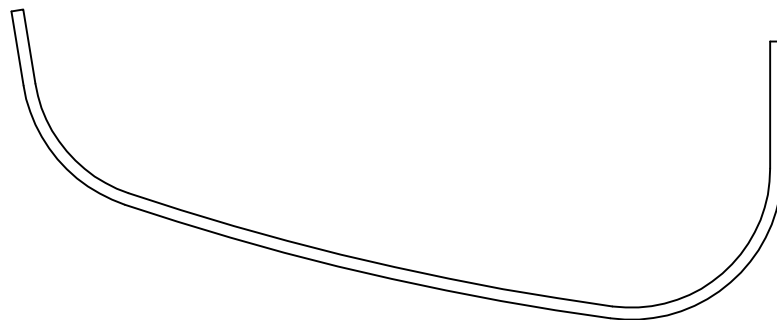

SCALE 1:1

BUMPER REAR

COMPANY : MAHINDRA & MAHINDRA  
PROJECT : SCORPIO SC/DC (EXPORT)



STAR AUTO INDUSTRIES  
G/2,G/3,G/8 ANSA INDUSTRIAL ESTATE  
SAKI VIHAR ROAD, SAKI NAKA

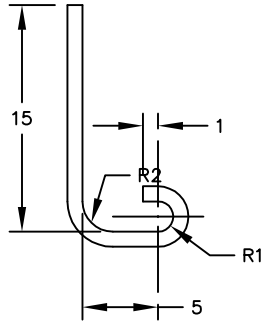

SCALE 2:1



SCALE 1:1

### REINFORCEMENT

COMPANY : TATA MOTORS

PROJECT : 1210

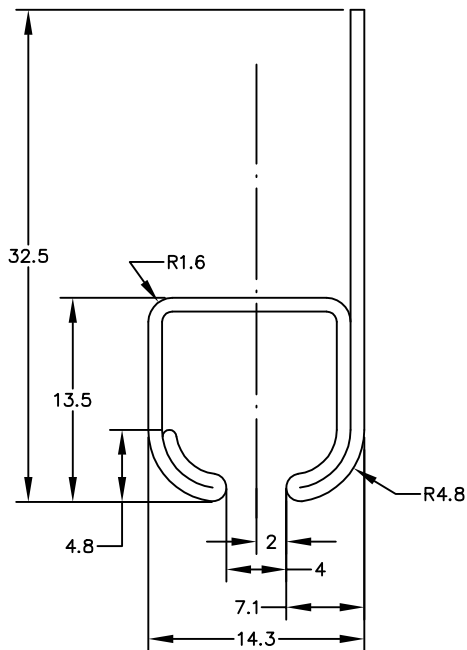

SCALE 2:1

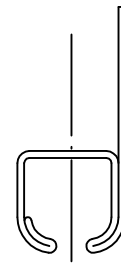

SCALE 1:1

### RETAINER FRONT TOP WIND SHIELD FRAME

COMPANY : MAHINDRA & MAHINDRA

PROJECT : COMMANDER, MM 540, CJ



STAR AUTO INDUSTRIES  
G/2,G/3,G/8 ANSA INDUSTRIAL ESTATE  
SAKI VIHAR ROAD, SAKI NAKA

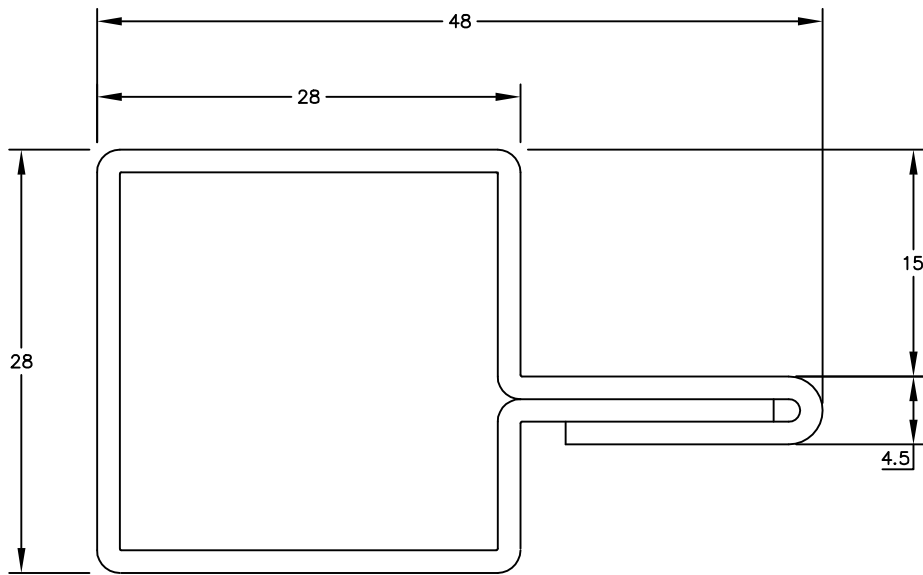

SCALE 1.5:1

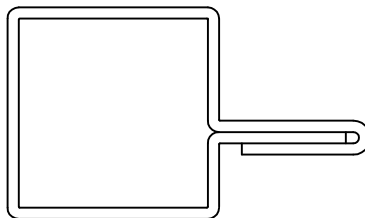

SCALE 1:1

SQUARE TUBE SINGLE FLANGE

COMPANY : MECHLONIC WELDERS PVT LTD

PROJECT : ELECTRONIC CABINET  
(STRUCTURAL SECTION)



STAR AUTO INDUSTRIES  
G/2,G/3,G/8 ANSA INDUSTRIAL ESTATE  
SAKI VIHAR ROAD, SAKI NAKA

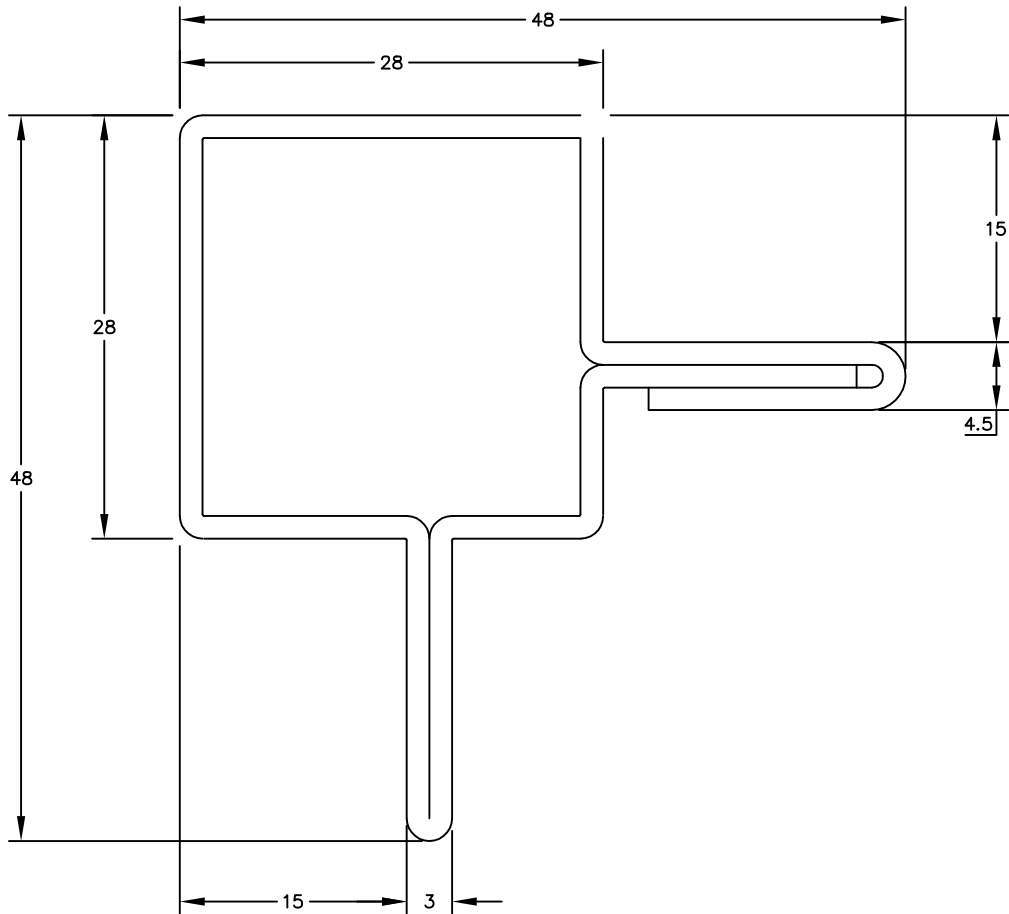

SCALE 1.5:1

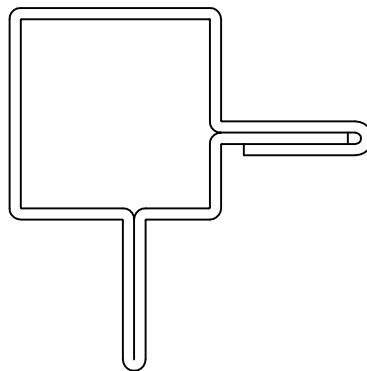

SCALE 1:1

STRUCTURAL SECTION

COMPANY : MECHLONIC WELDERS PVT LTD  
PROJECT : ELECTRONIC CABINET



STAR AUTO INDUSTRIES  
G/2,G/3,G/8 ANSA INDUSTRIAL ESTATE  
SAKI VIHAR ROAD, SAKI NAKA

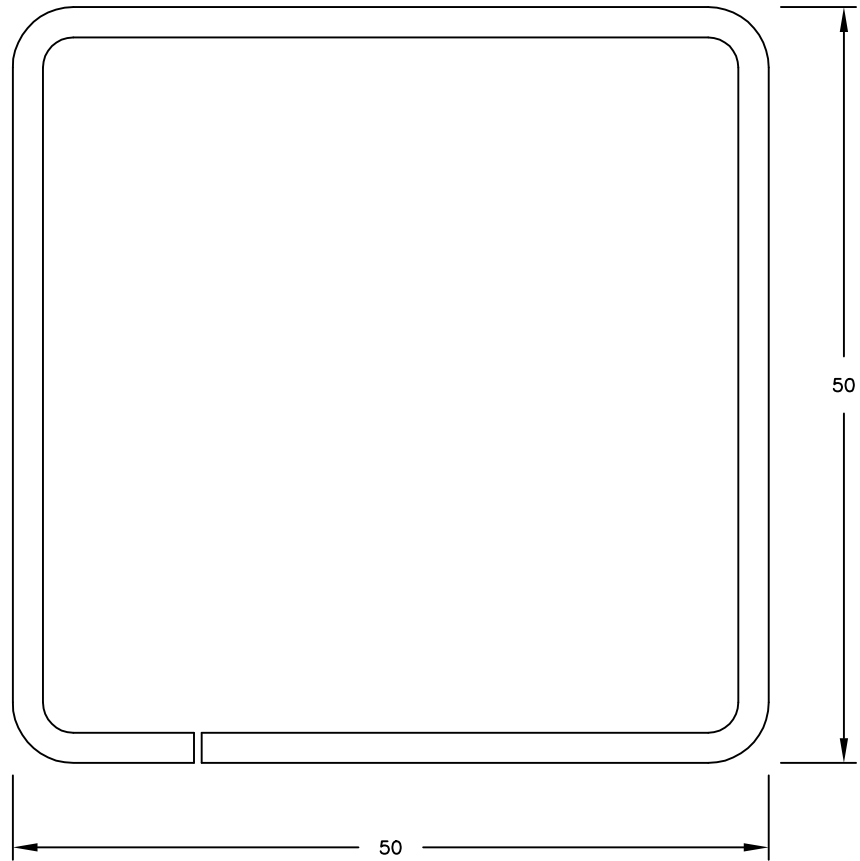

SCALE 1.5:1

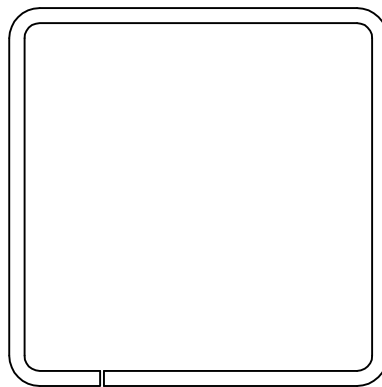

SCALE 1:1

REINFORCEMENT TUBE  
COMPANY : RUBY COACH



STAR AUTO INDUSTRIES  
G/2,G/3,G/8 ANSA INDUSTRIAL ESTATE  
SAKI VIHAR ROAD, SAKI NAKA

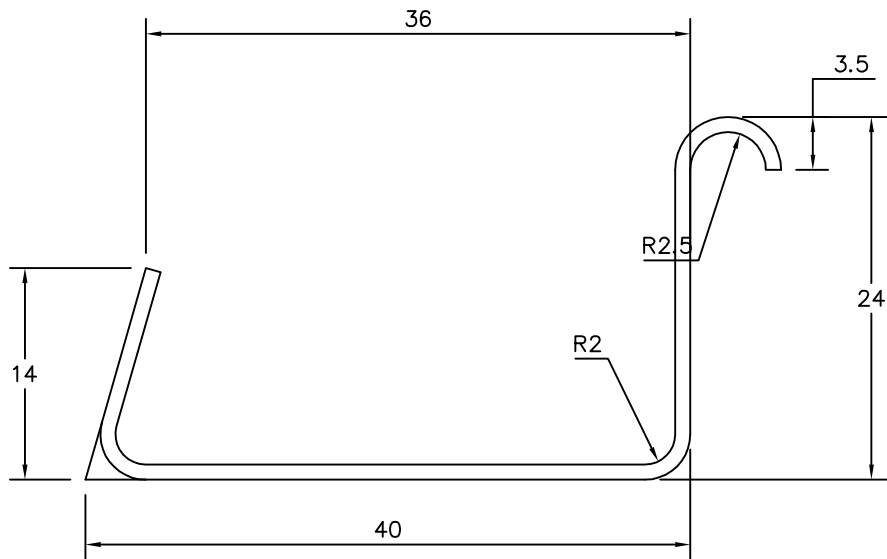

SCALE 2:1



SCALE 1:1

REINFORCEMENT FLOOR , BONNET

COMPANY : TATA MOTORS

PROJECT : CNG, EURO II



STAR AUTO INDUSTRIES  
G/2,G/3,G/8 ANSA INDUSTRIAL ESTATE  
SAKI VIHAR ROAD, SAKI NAKA

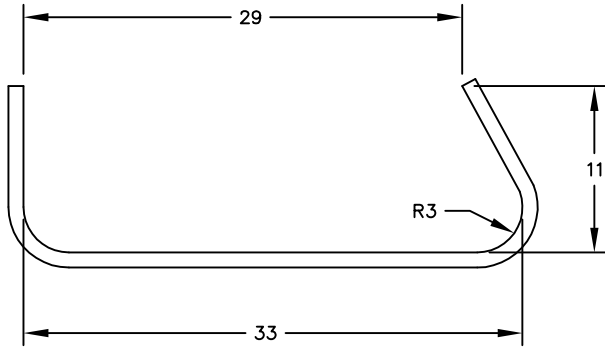

SCALE 2:1



SCALE 1:1

REINFORCEMENT FLOOR

COMPANY : TATA MOTORS

PROJECT : 2516, 1316

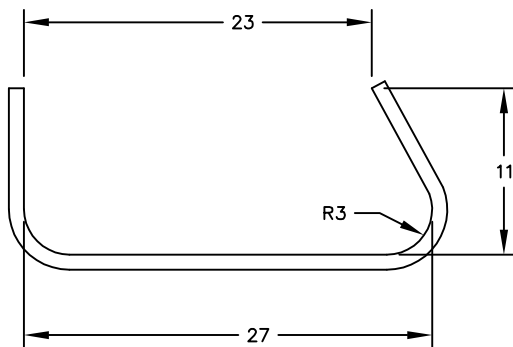

SCALE 2:1



SCALE 1:1

REINFORCEMENT FLOOR

COMPANY : TATA MOTORS

PROJECT : 407, 1210, 608



STAR AUTO INDUSTRIES  
G/2,G/3,G/8 ANSA INDUSTRIAL ESTATE  
SAKI VIHAR ROAD, SAKI NAKA

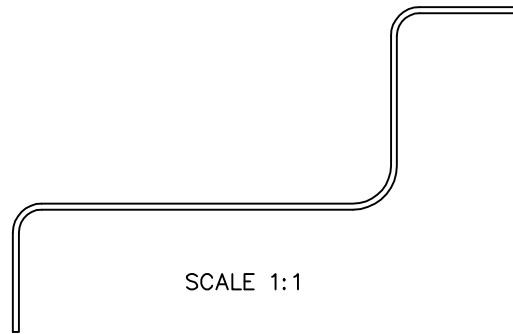
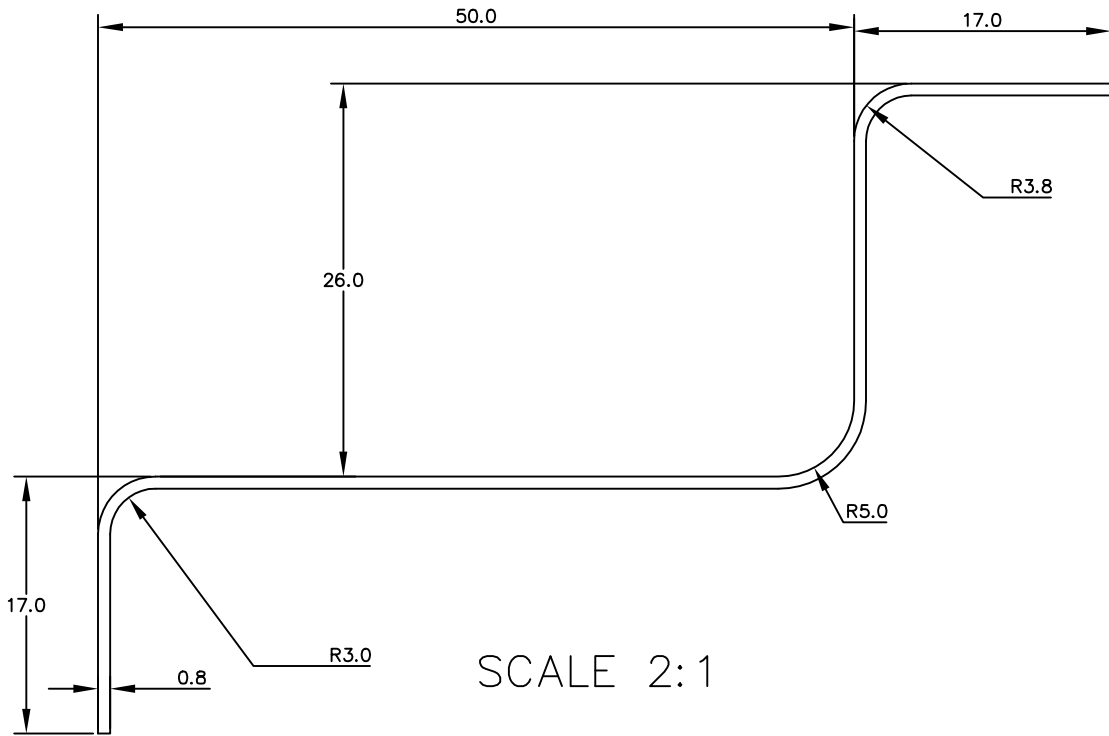

CROSS MEMBER VERTICAL FLOOR  
COMPANY : TATA MOTORS





STAR AUTO INDUSTRIES  
G/2,G/3,G/8 ANSA INDUSTRIAL ESTATE  
SAKI VIHAR ROAD, SAKI NAKA

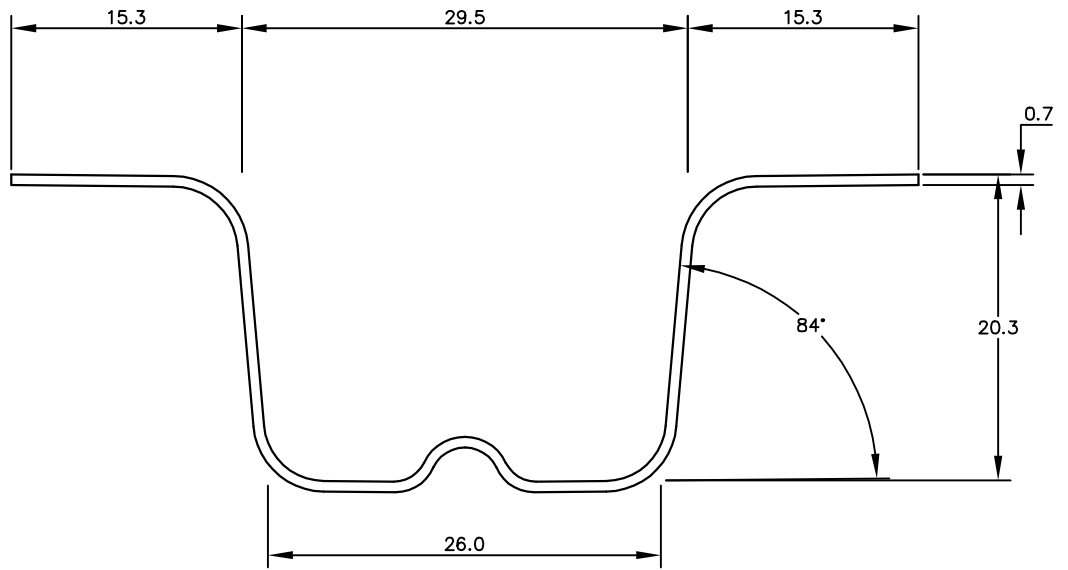

SCALE 2:1



SCALE 1:1

INTRUSION PANEL

COMPANY : TATA MOTORS



STAR AUTO INDUSTRIES  
G/2,G/3,G/8 ANSA INDUSTRIAL ESTATE  
SAKI VIHAR ROAD, SAKI NAKA

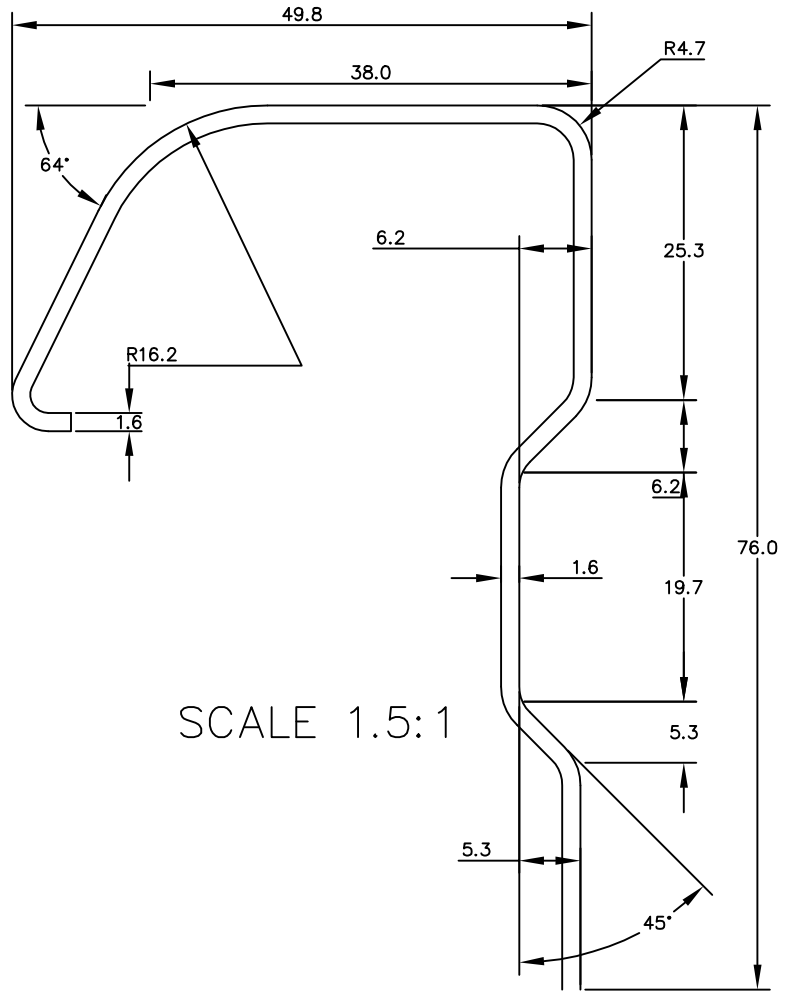

SCALE 1.5:1

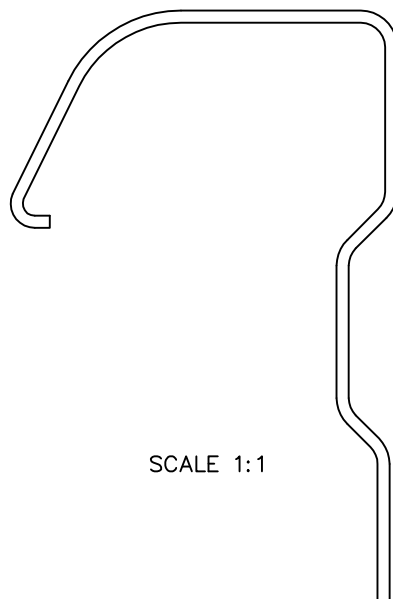

SCALE 1:1

RETAINER BODY SIDE

COMPANY : MAHINDRA & MAHINDRA



STAR AUTO INDUSTRIES  
G/2,G/3,G/8 ANSA INDUSTRIAL ESTATE  
SAKI VIHAR ROAD, SAKI NAKA

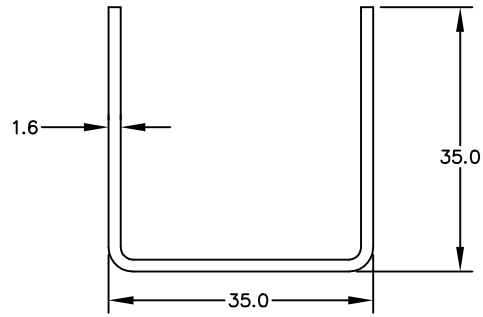

SCALE 1:1

### CRASH CHANNEL

COMPANY : MAHINDRA & MAHINDRA

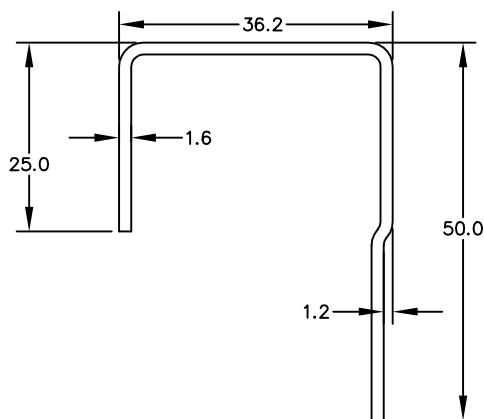

SCALE 1:1

### REINFORCEMENT CHANNEL

COMPANY : MAHINDRA & MAHINDRA



STAR AUTO INDUSTRIES  
G/2,G/3,G/8 ANSA INDUSTRIAL ESTATE  
SAKI VIHAR ROAD, SAKI NAKA

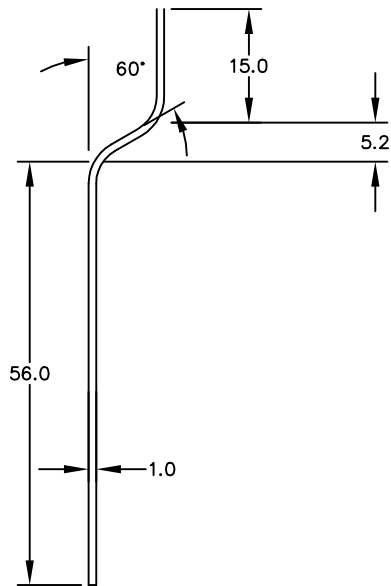

SCALE 1:1

### REINFORCEMENT BACK PANEL

COMPANY : MAHINDRA & MAHINDRA

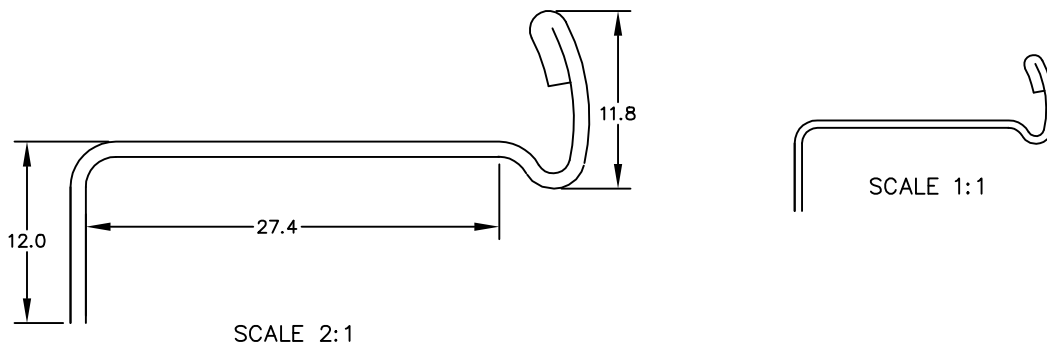

SCALE 2:1

SCALE 1:1

### DRIP CHANNEL FRONT

COMPANY : MAHINDRA & MAHINDRA



STAR AUTO INDUSTRIES  
G/2,G/3,G/8 ANSA INDUSTRIAL ESTATE  
SAKI VIHAR ROAD, SAKI NAKA

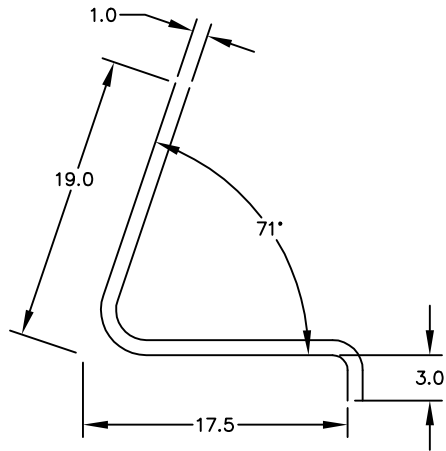

SCALE 2:1



SCALE 1:1

REINFORCEMENT SUPPORT BEEDING BOTOM

COMPANY : MAHINDRA & MAHINDRA

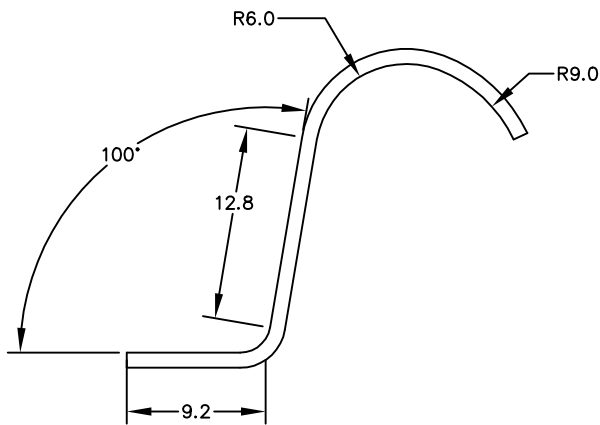

SCALE 2:1

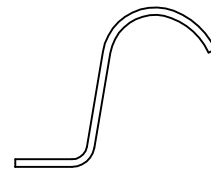

SCALE 1:1

SUPPORT BEEDING BOTOM

COMPANY : MAHINDRA & MAHINDRA



STAR AUTO INDUSTRIES  
G/2,G/3,G/8 ANSA INDUSTRIAL ESTATE  
SAKI VIHAR ROAD, SAKI NAKA

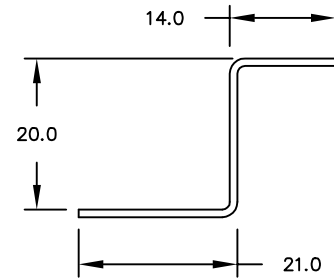
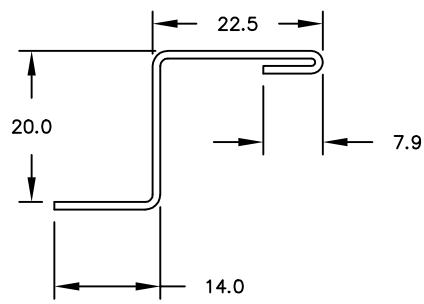

SCALE 1:1

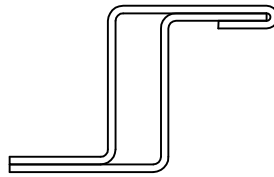

ASSY DOOR SASH – FRONT / REAR

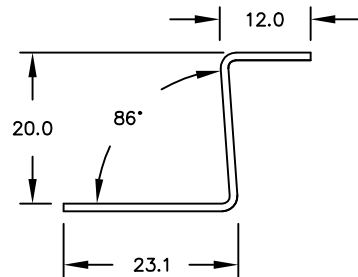
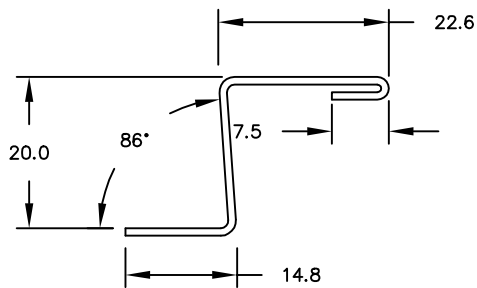

SCALE 1:1

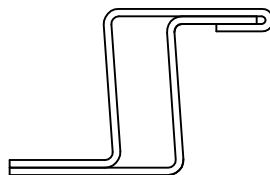

ASSY DOOR SASH CENTRE

COMPANY : MAHINDRA & MAHINDRA



STAR AUTO INDUSTRIES  
G/2,G/3,G/8 ANSA INDUSTRIAL ESTATE  
SAKI VIHAR ROAD, SAKI NAKA

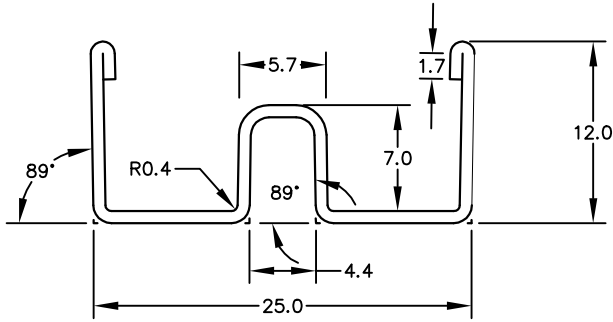

SCALE 2:1



SCALE 1:1

### WINDOW REAR FRAME

COMPANY : PINNACLE INDUSTRIES

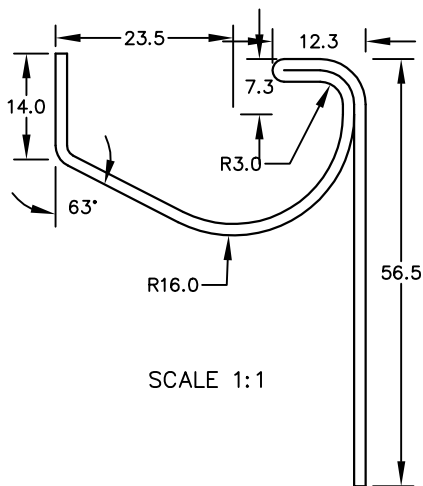

SCALE 1:1

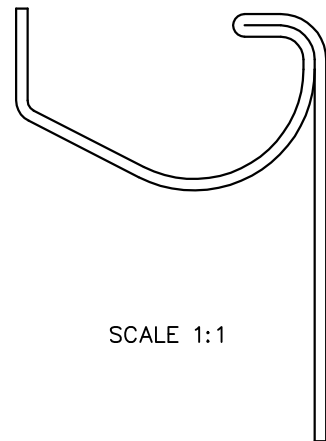

SCALE 1:1

### DOOR SLIDING CHANNEL

COMPANY : FORCE MOTORS



STAR AUTO INDUSTRIES  
G/2,G/3,G/8 ANSA INDUSTRIAL ESTATE  
SAKI VIHAR ROAD, SAKI NAKA

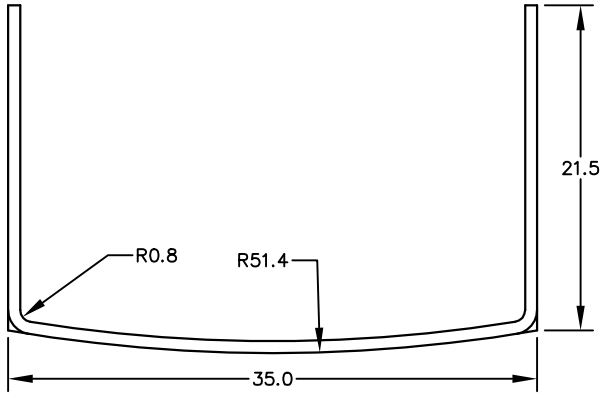

SCALE 2:1



SCALE 1:1

HORIZONTAL FRONT GRILLE BAR

COMPANY : H.M KOLKATA

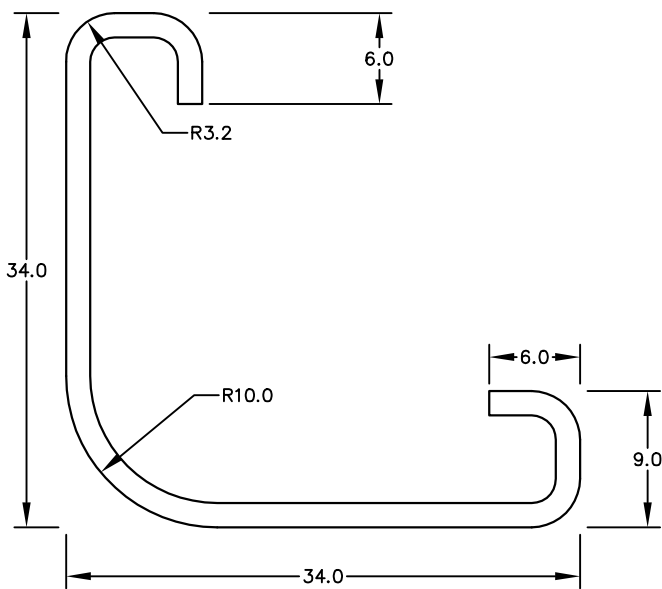

SCALE 2:1

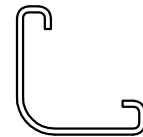

SCALE 1:1

RETAINER

COMPANY : EICHER MOTORS





STAR AUTO INDUSTRIES  
G/2,G/3,G/8 ANSA INDUSTRIAL ESTATE  
SAKI VIHAR ROAD, SAKI NAKA

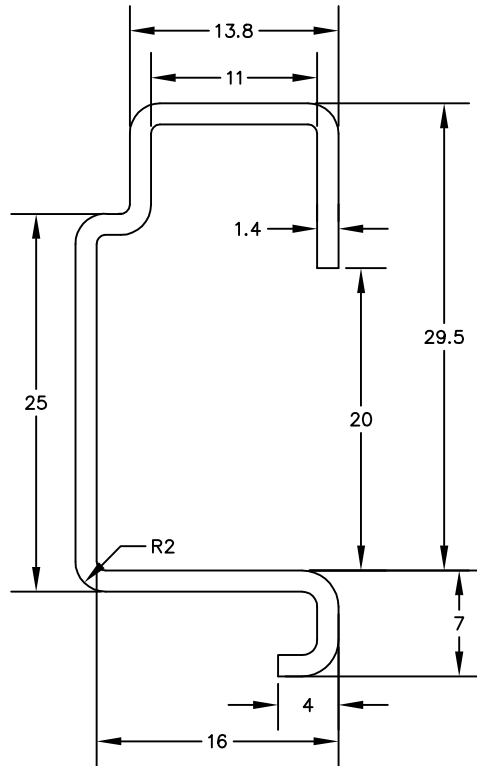

SCALE 2:1

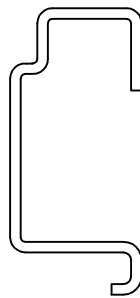

SCALE 1:1

RAIL CENTRE

COMPANY : MAHINDRA & MAHINDRA

PROJECT : VOYAGER



STAR AUTO INDUSTRIES  
G/2,G/3,G/8 ANSA INDUSTRIAL ESTATE  
SAKI VIHAR ROAD, SAKI NAKA

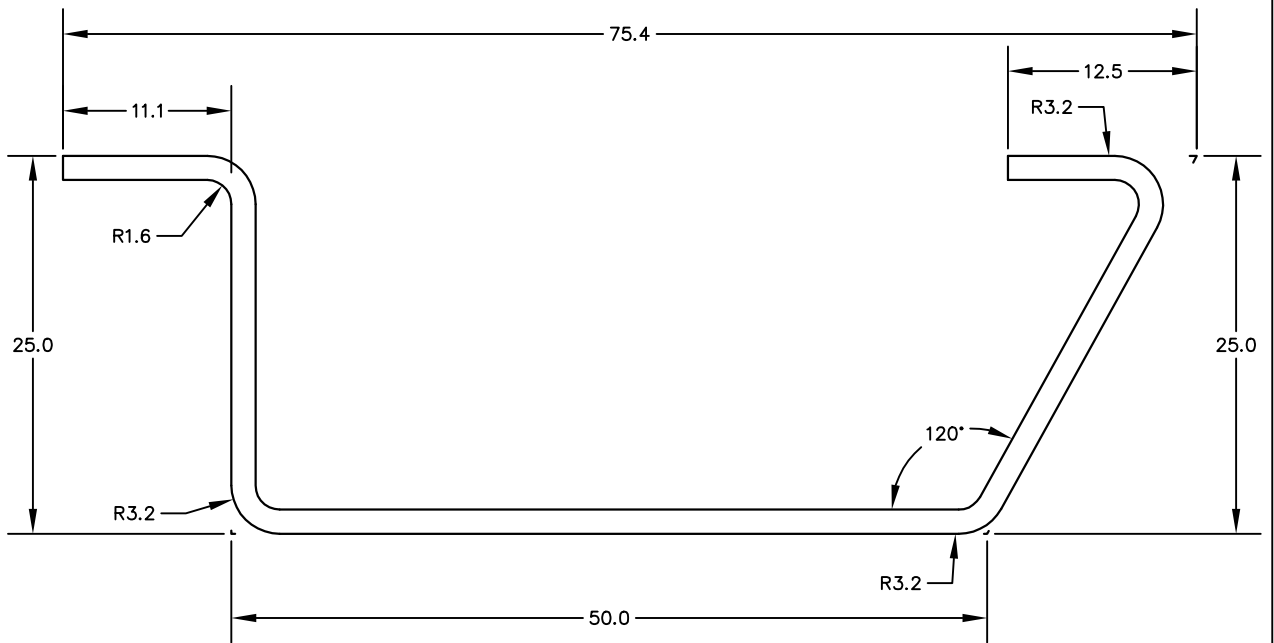

SCALE 2:1

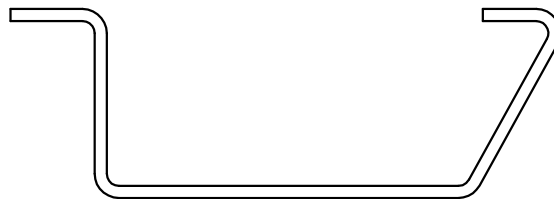

SCALE 1:1

IP MEMBER

COMPANY : MAHINDRA & MAHINDRA

PROJECT : CABKING



STAR AUTO INDUSTRIES  
G/2,G/3,G/8 ANSA INDUSTRIAL ESTATE  
SAKI VIHAR ROAD, SAKI NAKA

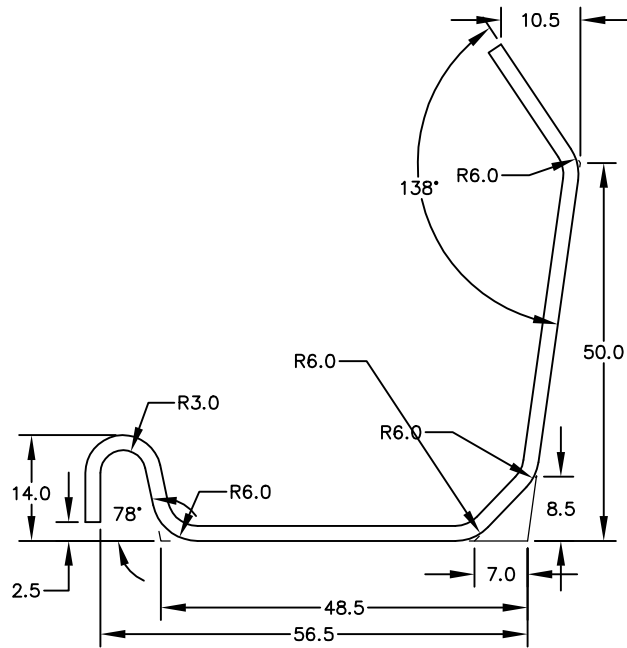

SCALE 1:1

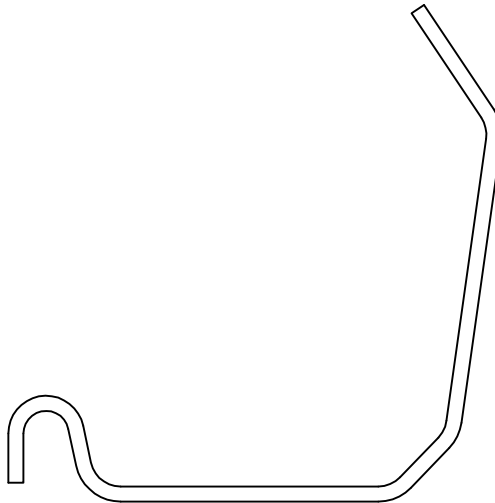

SCALE 1:1

IP MEMBER

COMPANY : ASHOK LEYLAND